

Application : Flash Light 、 Pump

用途：警示燈、泵浦

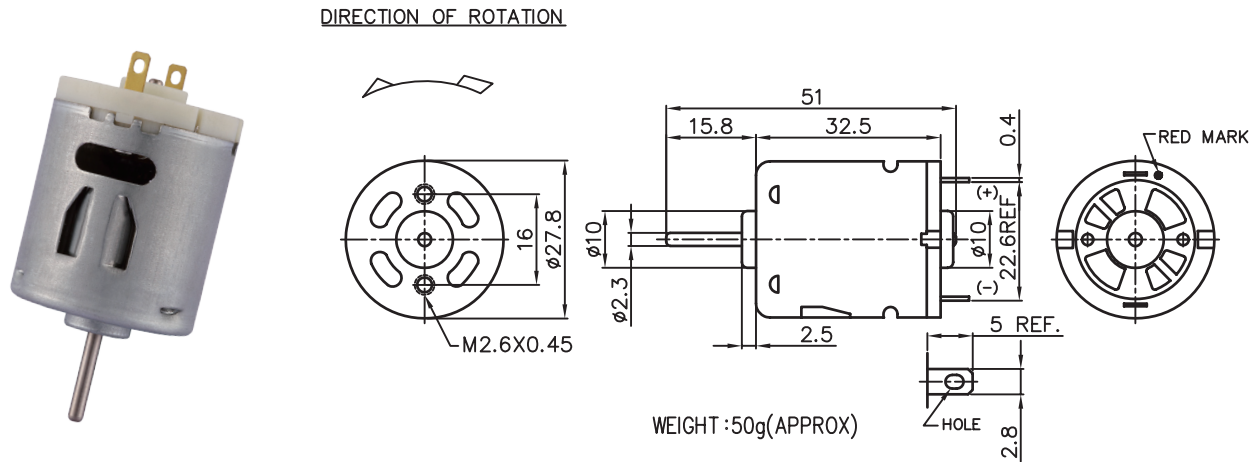

MODEL	VOLTAGE		NO LOAD		AT MAXIMUM EFFICIENCY						STALL		
	OPERATING RANGE	NOMINAL	SPEED rpm	CURRENT A	SPEED rpm	CURRENT A	TORQUE g-cm	TORQUE mN-m	OUTPUT W	EFF %	CURRENT A	TORQUE g-cm	TORQUE mN-m
MD3N-3745	1.2 - 3.6	3.6V CONSTANT	12500	0.80	9900	2.55	55	5.39	5.67	61	9.54	264	25.88
MS3N-2880	6.0 - 12.0	6.0V CONSTANT	12000	0.35	9900	1.57	57	5.59	5.90	64	8.18	363	35.59
MP3N-2495	3.0 - 12.0	6.0V CONSTANT	9800	0.30	8000	1.15	50	4.90	4.16	60	5.78	309	30.29
MP3N-3260	3.0 - 6.0	6.0V CONSTANT	15000	0.55	12200	3.38	98	9.61	12.34	62	14.89	524	51.37

馬達的出軸長度及性能參數，EMC 對策可依客人要求做調整，詳情可詢問相關業務人員。
Please inquire your sales representative for output, performance and EMC solution.

